

Circuits (ENGG1203)

1 Basics

We use a simple model as a starting point to discuss electronic circuits, which is shown on Figure 1.

FIGURE 1 – Fundamental circuit model

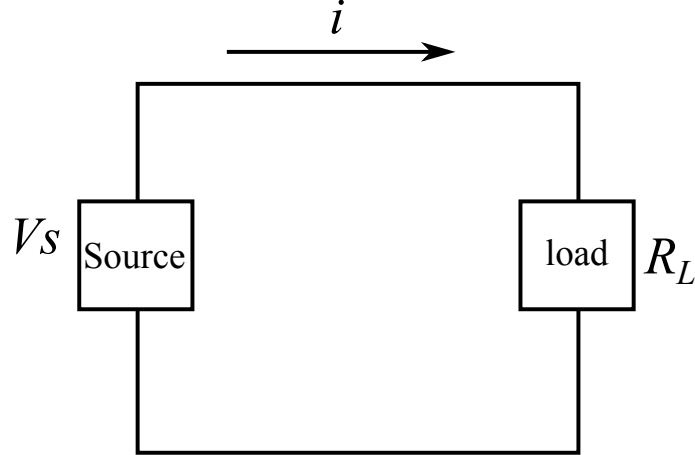

A basic circuit is made up of a source which provides voltage across its terminals, denoted by V_s , and a load connected to the source which presents a resistance R_L to the current i flowing as indicated around a closed loop.

1.1 Current

The current i results from the stream of electric charge around the closed loop shown on Figure 1. The mathematic definition is equal to the amount of charge, Q , passing through a cross-section per second and it can be expressed as

$$i = \frac{dQ}{dt} \quad (1.1)$$

The unit of charge is Coulomb. One Coulomb is equivalent to 6.24×10^{18} electrons. The unit of current is ampere, **A**. 1 Ampere = 1 Coulomb/sec.

1.1.1 Ideal DC Current Source

The current source is a device that can provide a certain amount of current to a circuit. The symbol for a DC current source and the i / v characteristic curve of an ideal current source are shown on Figure 2.

1.2 Voltage

Moving electrons along a conductor requires some amount of work that must be somehow supplied by an electromotive force provided by a battery or similar device. The electromotive force is the potential difference(voltage) between two points or across a component in circuit. The mathematical definition of voltage is given by

$$v = \frac{dW}{dQ} \quad (1.2)$$

where work(W) is measured in Joules and charge(Q) in Coulombs. Basically, the voltage is measured in volts(V) and $1\text{ volt} = 1 \frac{\text{Joule}}{\text{Coulomb}} = 1 \frac{\text{Newton meter}}{\text{Ampere second}}$

FIGURE 2 – Ideal DC Current Source

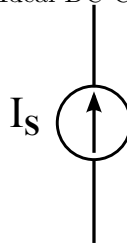

1.2.1 Ideal DC Voltage Source

The voltage provided by a voltage source(usually battery) is constant in time and thus it is called DC voltage. In its ideal implementation the battery provides a specific voltage at all times and for all loads. The symbols of an ideal DC voltage source are shown as follows :

FIGURE 3 – Ideal DC Voltage Source

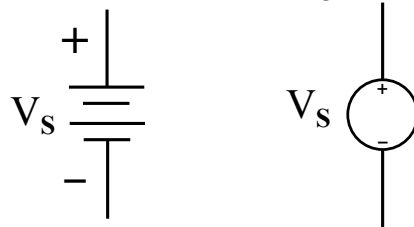

1.3 Ideal resistor

The ideal resistor is a passive, linear, two-terminal device whose resistance follows Ohm’s law given by,

$$v = iR, \tag{1.3}$$

which states that the voltage across an element is directly proportional to the current flowing through the element. The constant of proportionality is the resistance R provided by the element. The resistance is measured in Ohms, Ω , and

$$1\Omega = 1\frac{V}{A}, \tag{1.4}$$

the symbol for a resistor is,

FIGURE 4 – Ideal resistor

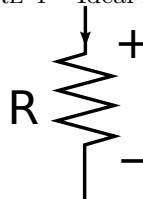

1.4 Resistor Color Code

The colored painted bands produce a system of identification generally known as a **Resistors Color Code**. The resistor color code markings are always read one band at a time starting from the left to the right, with the larger width tolerance band oriented to the right side indicating its tolerance. By matching the color of the first band with its associated number in the digit column of the color chart below, the first digit is identified and this represents the first digit of the resistance value.

Again, by matching the color of the second band with its associated number in the digit column of the color chart, we get the second digit of the resistance value and so on. Then the resistor color code is read from left to right as illustrated below

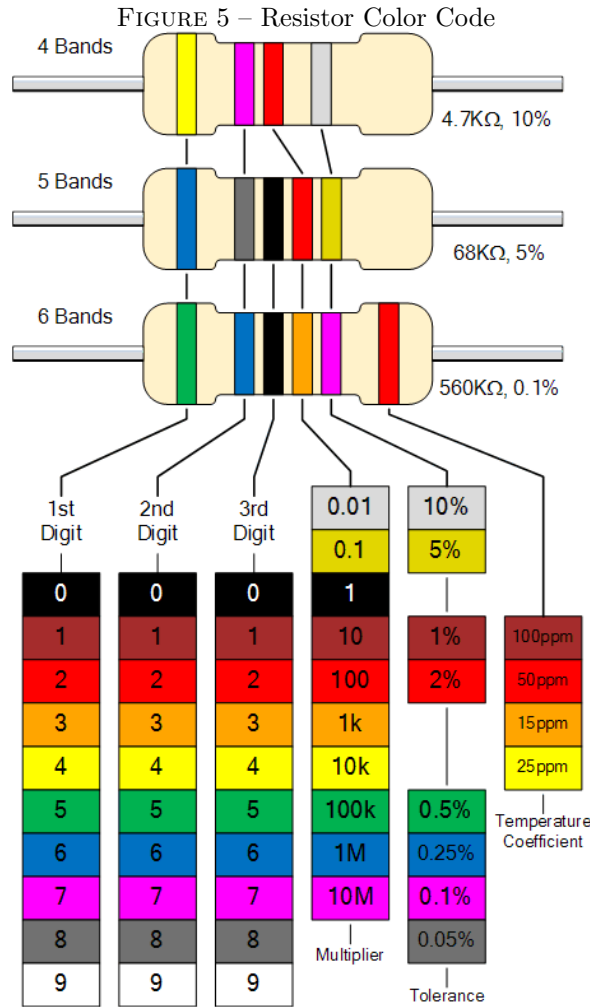

FIGURE 6 – Color Code Table

Colour	Digit	Multiplier	Tolerance
Black	0	1	
Brown	1	10	± 1%
Red	2	100	± 2%
Orange	3	1,000	
Yellow	4	10,000	
Green	5	100,000	± 0.5%
Blue	6	1,000,000	± 0.25%
Violet	7	10,000,000	± 0.1%
Grey	8		± 0.05%
White	9		
Gold		0.1	± 5%
Silver		0.01	± 10%
None			± 20%

For example, a resistor has the following colored markings :

$$\text{Yellow Violet Red} = 4\ 7\ 2 = 4\ 7 \times 10^2 = 4700\Omega \text{ or } 4\text{k}7.$$

1.5 Power

When current flows through a resistor, energy is irreversibly lost (or we say dissipated) in overcoming the resistance. The dissipated power shows up as heat most of the time. The mathematical definition of power is the rate at which energy is delivered. It can be expressed as

$$P = \frac{dW}{dt}, \quad (1.5)$$

The units for power are *Joules/sec* or Watts, W . ($1 \text{ Joules/sec} = 1W$) Power can be related to voltage and current by rewriting Eq.(1.5) as,

$$P = \frac{dW}{dt} = \frac{dW}{dQ} \frac{dQ}{dt} = vi, \quad (1.6)$$

Then substitute Ohm's law in Eq.(1.6), we will get the power dissipated in a resistor of resistance R is a quadratic function of either i or v and they can be expressed by

$$P = i^2 R \quad \text{or} \quad P = \frac{v^2}{R} \quad (1.7)$$

Power rating is a fundamental constraint of resistors and electronic devices in general. The power rating is referred to the maximum power that the device can dissipate without adversely affecting its operation. When the power rating is exceeded, the resistor overheats and it is destroyed by burning up.

2 Kirchhoff's Laws

Kirchhoff's laws also known as Kirchhoff's Current Law (KCL) and Kirchhoff's Voltage Law (KVL) are based respectively on the conservation of charge and the conservation of energy and are derived from Maxwell's equations. They along with Ohm's law present the fundamental tools for circuit analysis.

2.1 Kirchhoff's Current Law

The current flowing out of any node in a circuit must be equal to the current flowing into the node. It is expressed mathematically as

$$\sum_{n=1}^N i_n = 0 \quad (2.1)$$

where N is the number of branches that are connected to the node.

2.2 Kirchhoff's Voltage Law

The algebraic sum of voltages around a closed loop is zero. It is expressed mathematically as

$$\sum_{n=1}^N v_n = 0 \quad (2.2)$$

where N is the number of voltages in the loop. The number of voltages is equal to the number of elements encountered as we go around the loop.

Next we will solve for the circuit shown on Figure 7

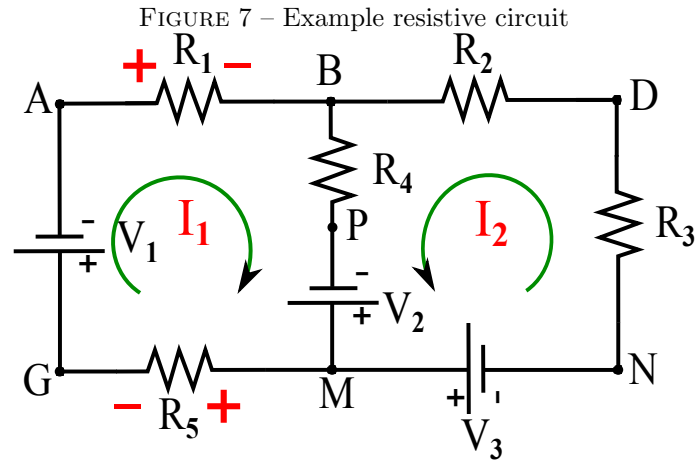

$$R_1 = 80\Omega, R_2 = 10\Omega, R_3 = 20\Omega, R_4 = 90\Omega, R_5 = 100\Omega, V_1 = 12V, V_2 = 24V, V_3 = 36V$$

Apply Kirchhoff's laws.

- Start with the nodes.

1. The middle node P is already accounted for since we assigned the current above and below it the same value, I_1 . This is just Kirchhoff's current law which says that the current going into a node is equal to that going out.
2. The bottom and top nodes B and M are exactly the same and KCL for them is :

$$I - I_1 + I_2 = 0$$
 since at node B, current I and I_2 flow in the node B and I_1 flows out the node B.

- Next let's apply KVL to the three loops

1. **Loop 1 (I_1 loop)** : voltage source V_1 , V_2 and resistors R_1 , R_4 , R_5

$$\begin{aligned} V_1 + I_1 R_1 + (I_1 + I_2) R_4 - V_2 + I_1 R_5 &= 0 \\ \Rightarrow 12 + 80I_1 + 90I_1 + 90I_2 - 24 + 100I_1 &= 0 \\ \Rightarrow 270I_1 + 90I_2 &= 12 \end{aligned}$$

2. **Loop 2 (I_2 loop)** : voltage source V_2 , V_3 and resistors R_2 , R_3 , R_4

$$\begin{aligned} V_3 + I_2 R_3 + I_2 R_2 + (I_1 + I_2) R_4 - V_2 &= 0 \\ \Rightarrow 36 + 20I_2 + 10I_2 + 90I_1 + 90I_2 - 24 &= 0 \\ \Rightarrow 90I_1 + 120I_2 &= -12 \end{aligned}$$

- Calculate the required parameters using Ohm's law and relevant formulas.

$$I_1 = \frac{14}{135} A$$

$$I_2 = -\frac{8}{45} A$$

3 Voltage divider : Series Connection of Resistors

The voltage divider circuit is the most convenient means of passively stepping down the voltage from a fixed voltage source.

$$I = \frac{V}{R_1 + R_2}$$

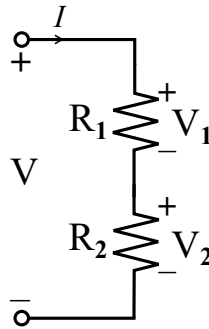

$$V_1 = R_1 I = \frac{R_1}{R_1 + R_2} V$$

$$V_2 = R_2 I = \frac{R_2}{R_1 + R_2} V$$

By considering a circuit where we are using N resistors connected in series, we can show that the equivalent resistance is the sum of the resistances.

$$R_{eq} = \sum_{n=1}^N R_n = R_1 + R_2 + \dots + R_N \tag{3.1}$$

4 Current Divider : Parallel connection of resistors

The schematic on Figure 8 shows a simple current divider circuit. Here the two resistors R_1 and R_2 are connected in parallel. Lets determine the current I_1 and I_2 flowing in the two resistors.

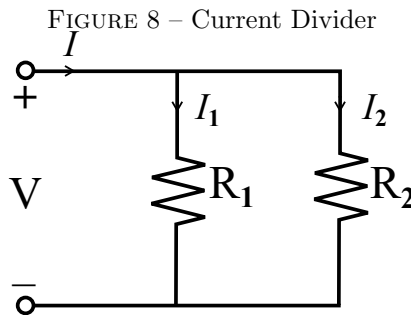

$$V = (R_1 \parallel R_2) I$$

$$I_1 = \frac{V}{R_1} = \frac{R_1 \parallel R_2}{R_1} I = \frac{R_2}{R_1 + R_2} I$$

$$I_2 = \frac{R_1}{R_1 + R_2} I$$

For N resistors connected in parallel the equivalent resistance is

$$\frac{1}{R_{eq}} = \sum_{n=1}^N \frac{1}{R_n} = \frac{1}{R_1} + \frac{1}{R_2} + \dots + \frac{1}{R_N} \tag{4.1}$$

Note that the equivalent resistance R_{eq} is smaller than the smallest resistance in the parallel arrangement.

The equivalent conductance of N resistors connected in parallel is

$$G_{eq} = \sum_{n=1}^N G_n = G_1 + G_2 + \dots + G_N \tag{4.2}$$

where $G_n = \frac{1}{R_n}$. The current flowing through resistor R_n is

$$i_n = i \frac{G_n}{G_{eq}} \tag{4.3}$$

5 Advanced methods for circuit analysis

5.1 Node Method & Mesh Method

With the help of Kirchhoff's laws and Ohm's law, we can analyze any circuit to determine the currents and voltages. For formal circuit analysis, the challenge is to derive the smallest set of simultaneous equations that completely define the operating characteristics of a circuit.

The following part, we will develop two very powerful methods for analyzing any circuit : The **node method** and the **mesh method**. We will explain the steps to solve the circuit problem shown in Figure 2.

5.1.1 The Node Method

Voltage is defined as the potential difference between two points. When we talk about the voltage at a certain point, we imply that the measurement is performed between that point and some other points in the circuit. Usually, this reference point is defined as **ground**.

Node method(or node voltage method) is an efficient circuit analysis method based on KCL, KVL, and Ohm's laws. Steps for using node method to analyze circuit are as follows :

1. Label all the circuit parameters and distinguish the unknown parameters from the known ones.
2. Identify all nodes of the circuit.
3. Choose a reference node(Ground) and assign to it a potential of 0V. All other voltages in the circuit are measured with respect to the reference node.
4. Label the voltage at all other nodes.
5. Assign and label polarities.
6. Apply KCL at each node and express the branch currents in terms of the node voltages.
7. Solve the resulting simultaneous equations for the node voltages.
8. Obtain the branch currents by Ohm's law.

We will use the circuit of Figure 9 for a step by step demonstration of the node method.

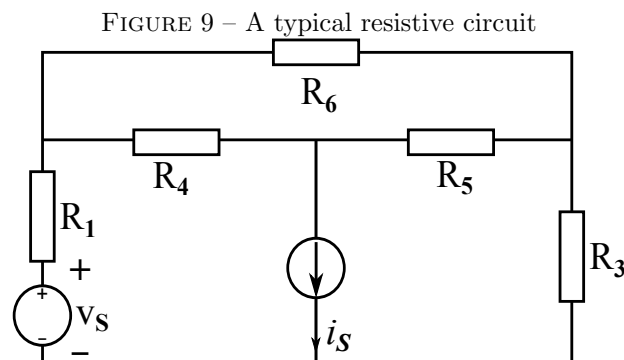

Figure 10. shows the implementation of steps 1 and 2. We have labeled all elements and identified all relevant nodes in the circuit.

The third step is to select one of the identified nodes as the reference node. We have four different choices for the assignment. In principle any of these nodes may be selected as the reference node. However, some nodes are more useful than others. Useful nodes are the ones which make the problem **easier to understand and solve**. There are a few general guidelines that we need to remember as we make the selection of the reference node.

- * A useful reference node is one which should have the largest number of elements connected to it.
- * A useful reference node is one which should be connected to the maximum number of voltage sources.

In this example the selection of node **0** as the reference node is the best choice. (you could also select node **1** as our reference node.)

Next, we should label the voltages at the selected nodes. Figure 11 shows the circuit with the labeled nodal voltages. The reference node is assigned voltage 0 Volts indicated by the ground symbol. The remaining node voltages are labeled V_{S1} , V_{S2} , V_{S3} .

For the next step we assign current flow and polarities, see Figure 12. The circuit shown on Figure 4 is completely defined now. Once we determine the values for the node voltages V_{S1} , V_{S2} , V_{S3} . we will be able to completely characterize this circuit. So let's go on to calculate the node voltages by applying KCL at the designated nodes.

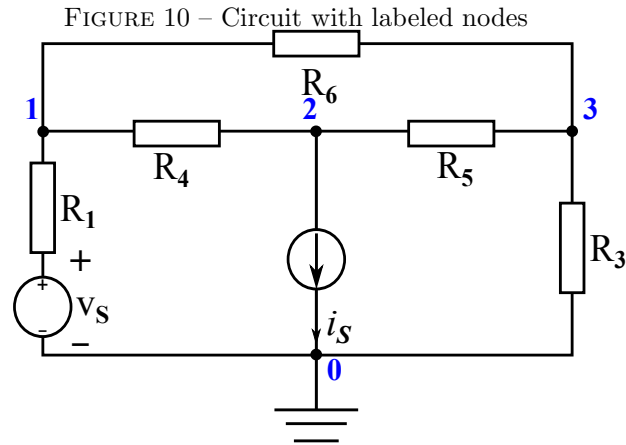

FIGURE 11 – Circuit with assigned nodal voltages v_6

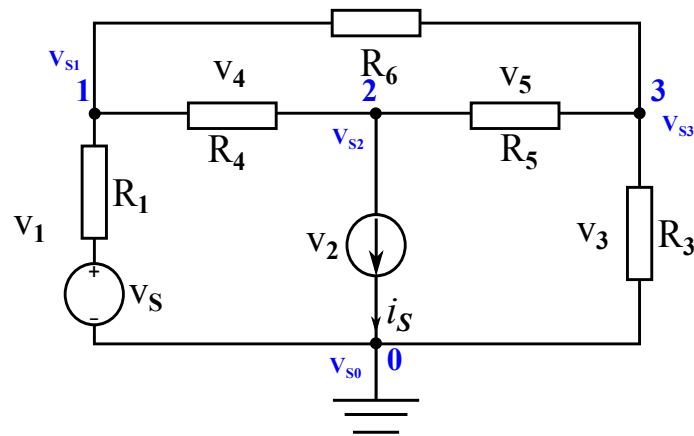
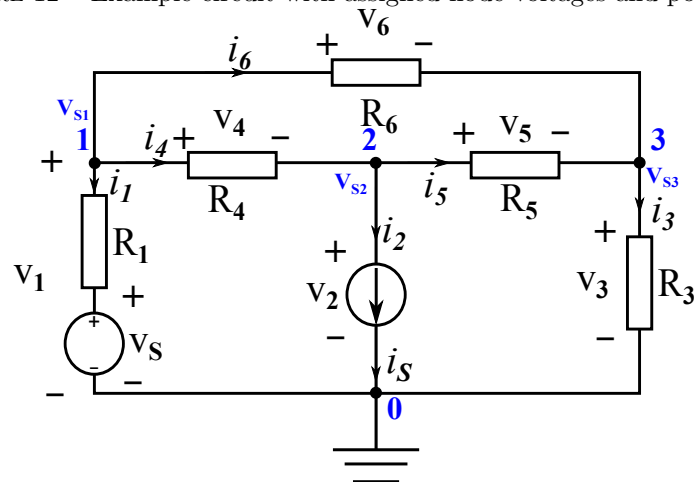

FIGURE 12 – Example circuit with assigned node voltages and polarities



According to the Ohm's law, the currents i_1 to i_6 are expressed in terms of the voltages v_{s1} , v_{s2} , v_{s3} as follows.

$$i_1 = \frac{v_1 - v_s}{R_1} \tag{5.1}$$

$$i_2 = i_s \tag{5.2}$$

$$i_3 = \frac{v_3}{R_3} = \frac{v_{s3}}{R_3} \quad (5.3)$$

$$i_4 = \frac{v_4}{R_4} = \frac{v_{s1} - v_{s2}}{R_4} \quad (5.4)$$

$$i_5 = \frac{v_5}{R_5} = \frac{v_{s2} - v_{s3}}{R_5} \quad (5.5)$$

$$i_6 = \frac{v_6}{R_6} = \frac{v_{s1} - v_{s3}}{R_6} \quad (5.6)$$

KCL at node **1,2,3** we will get :

$$i_1 + i_4 + i_6 = 0 \quad (5.7)$$

$$i_2 - i_4 + i_5 = 0 \quad (5.8)$$

$$i_3 - i_5 - i_6 = 0 \quad (5.9)$$

By combining Eqs. (5.1) – (5.9) we obtain :

$$\left(\frac{1}{R_1} + \frac{1}{R_4} + \frac{1}{R_6}\right)v_{s1} - \frac{1}{R_4}v_{s2} - \frac{1}{R_6}v_{s3} = \frac{v_s}{R_1} \quad (5.10)$$

$$-\frac{1}{R_4}v_{s1} + \left(\frac{1}{R_4} + \frac{1}{R_5}\right)v_{s2} - \frac{1}{R_5}v_{s3} = -i_s \quad (5.11)$$

$$-\frac{1}{R_6}v_{s1} - \frac{1}{R_5}v_{s2} + \left(\frac{1}{R_3} + \frac{1}{R_5} + \frac{1}{R_6}\right)v_{s3} = 0 \quad (5.12)$$

If we assign $R_1 = R_5 = 2\Omega$, $R_3 = 6\Omega$, $R_4 = 4\Omega$, $R_6 = 1\Omega$, $v_s = 14V$, $i_s = 2A$

we can easily get the following equations by substituting the known parameters into the Eqs. (5.10) – (5.12)

$$1.75v_{s1} - 0.25v_{s2} - v_{s3} = 7 \quad (5.13)$$

$$-0.25v_{s1} + 0.75v_{s2} - 0.5v_{s3} = -2 \quad (5.14)$$

$$-v_{s1} - 0.5v_{s2} + \frac{5}{3}v_{s3} = 0 \quad (5.15)$$

The solutions of the above equations are as follows :

$$v_{s1} = 8V, v_{s2} = 4V, v_{s3} = 6V$$

The voltage of each branch(v_1 to v_6) :

$$v_1 = v_{s1} = 8V$$

$$v_2 = v_{s2} = 4V$$

$$v_3 = v_{s3} = 6V$$

$$v_4 = v_{s1} - v_{s2} = 8 - 4 = 4V$$

$$v_5 = v_{s2} - v_{s3} = 4 - 6 = -2V$$

$$v_6 = v_{s1} - v_{s3} = 8 - 6 = 2V$$

The currents across each component are :

$$i_1 = \frac{1}{R_1}(v_1 - v_s) = 0.5 \times (8 - 14) = -3A$$

$$i_2 = i_s = 2A$$

$$i_3 = \frac{1}{R_3}v_3 = \frac{1}{6} \times 6 = 1A$$

$$i_4 = \frac{1}{R_4}v_4 = 0.25 \times 4 = 1A$$

$$i_5 = \frac{1}{R_5}v_5 = 0.5 \times (-2) = -1A$$

$$i_6 = \frac{1}{R_6} v_6 = 1 \times 2 = 2A$$

Using KCL rule to check the result

KCL at node **1** :

$$\sum i = i_1 + i_4 + i_6 = -3 + 1 + 2 = 0$$

KCL at node **2** :

$$\sum i = i_2 - i_4 + i_5 = 2 - 1 - 1 = 0$$

KCL at node **3** :

$$\sum i = i_3 - i_5 - i_6 = 1 + 1 - 2 = 0$$

Thus, the solution is right.

5.1.2 The Mesh Method

The mesh method uses the mesh currents as the circuit variables. The procedure for obtaining the solution is similar to that followed in the Node method and the various steps are given below.

1. Label all the circuit parameters and distinguish the unknown parameters from the known ones.
2. Identify all meshes of the circuit.
3. Assign mesh currents and label polarities.
4. Apply KVL at each mesh and express the voltages in terms of the mesh currents.
5. Solve the resulting simultaneous equations for the mesh currents.
6. Obtain the voltages by Ohm's law.

A **mesh** is defined as a loop which does not contain any other loops. The circuit example has seven loops but only three meshes as shown on Figure 13. Note that we have assigned a ground potential to a certain part of the circuit. Since the definition of ground potential is fundamental in understanding circuits this is a good practice and thus will continue to designate a reference (ground) potential as we continue to design and analyze circuits regardless of the method used in the analysis.

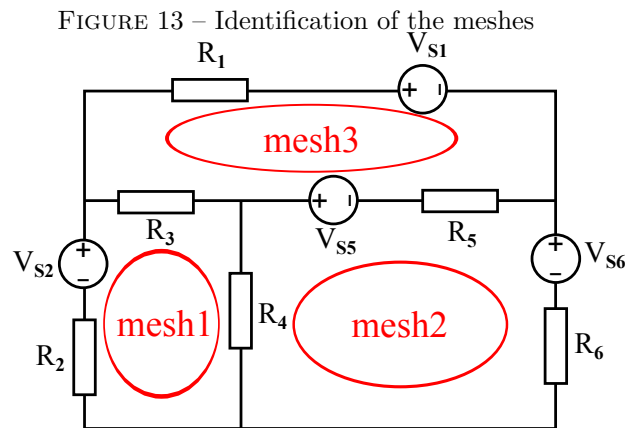

The meshes of interest are mesh1, mesh2 and mesh3. For the next step we will assign mesh currents, define current direction and voltage polarities.

The direction of the mesh currents i_{m1}, i_{m2}, i_{m3} is defined in the clockwise direction as shown on Figure 14. The definition for the current direction is arbitrary but it helps if we maintain consistence in the way we define these current directions.

We first assume that the voltages drop of each branch are v_1 to v_6 , and according to the Ohm's law :

$$v_1 = R_1 i_1 + V_{s1} = R_1 i_{m1} + V_{s1} \tag{5.16}$$

$$v_2 = R_2 i_2 - V_{s2} = R_2 \tag{5.17}$$

$$v_3 = R_3 i_3 = R_3 (i_{m2} - i_{m1}) \tag{5.18}$$

FIGURE 14 – labeling mesh current direction

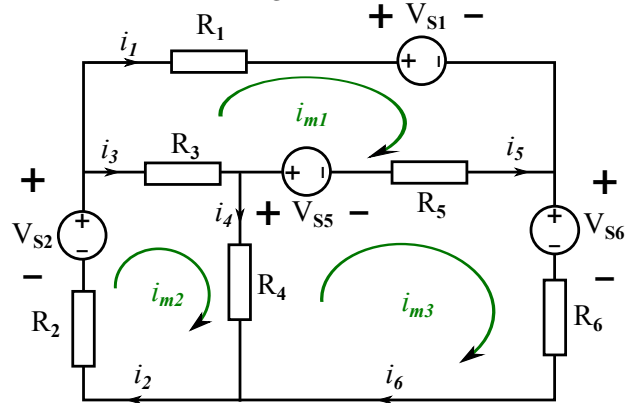

$$v_4 = R_4 i_4 = R_4 (i_{m2} - i_{m1}) \tag{5.19}$$

$$v_5 = R_5 i_5 + V_{s5} = R_5 (i_{m3} - i_{m1}) + V_{s5} \tag{5.20}$$

$$v_6 = R_6 i_6 + V_{s6} = R_6 i_{m3} + V_{s6} \tag{5.21}$$

Apply KVL to mesh1, mesh2 and mesh3 :

$$v_1 - v_3 - v_5 = 0 \tag{5.22}$$

$$v_2 + v_3 + v_4 = 0 \tag{5.23}$$

$$-v_4 + v_5 + v_6 = 0 \tag{5.24}$$

By combining Eqs. (5.16) – (5.24) we obtain :

$$(R_1 + R_3 + R_5) i_{m1} - R_3 i_{m2} - R_5 i_{m3} = V_{s5} - V_{s1} \tag{5.25}$$

$$-R_3 i_{m1} + (R_2 + R_3 + R_4) i_{m2} - R_4 i_{m3} = V_{s2} \tag{5.26}$$

$$-R_5 i_{m1} - R_4 i_{m2} + (R_4 + R_5 + R_6) i_{m3} = V_{s3} \tag{5.27}$$

If we assign $R_1 = R_2 = R_6 = 3\Omega$, $R_3 = 5\Omega$, $R_4 = 1\Omega$, $R_5 = 2\Omega$, $V_{s1} = 12V$, $V_{s2} = 10V$, $V_{s5} = 6V$, $V_{s6} = -20V$

$$10i_{m1} - 5i_{m2} - 2i_{m3} = -6 \tag{5.28}$$

$$-5i_{m1} + 9i_{m2} - i_{m3} = 10 \tag{5.29}$$

$$-2i_{m1} - i_{m2} + 6i_{m3} = 14 \tag{5.30}$$

Solve the equations we will get :

$$i_{m1} = 1A$$

$$i_{m2} = 2A$$

$$i_{m3} = 3A$$

The current of each branch (i_1 to i_6) :

$$i_1 = i_{m1} = 1A$$

$$i_2 = i_{m2} = 2A$$

$$i_3 = i_{m2} - i_{m1} = 2 - 1 = 1A$$

$$i_4 = i_{m2} - i_{m3} = 2 - 3 = -1A$$

$$i_5 = i_{m3} - i_{m1} = 3 - 1 = 2A$$

$$i_6 = i_{m3} = 3A$$

5.2 Equivalent Resistance

5.2.1 Thevenin’s Theorem

Any combination of batteries and resistances with two terminals can be replaced by a single voltage source e and a single series resistor r . The value of e is the **open circuit** voltage at the terminals, and the value of r is e divided by the current with the terminals short circuited.

5.2.2 $\Delta - Y$ and $Y - \Delta$ Conversions

In many circuit applications, we encounter components connected together in one of two ways to form a three-terminal network : the “Delta”, or Δ (also known as the “pi”, or Π) configuration, and the Y (also known as the T) configuration.

It’s possible to calculate the proper values of resistors necessary to form one kind of network(Δ or Y) that behaves identically to the other kind. That is, if we had two separate resistor networks, one is Δ -shape and the other is Y-shape, each with its resistors hidden from view, with nothing but the three terminals (A, B, and C) exposed for testing, the resistors could be sized for the two networks so that there would be no way to electrically determine one network apart from the other. In other words, equivalent Δ and Y networks behave identically. The equations used to convert one network to the other are

FIGURE 15 – Wye(Y) network

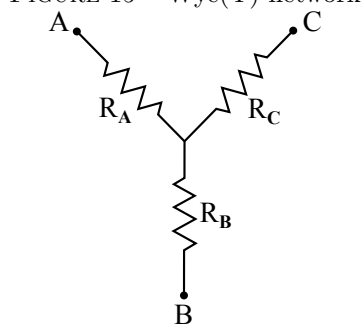
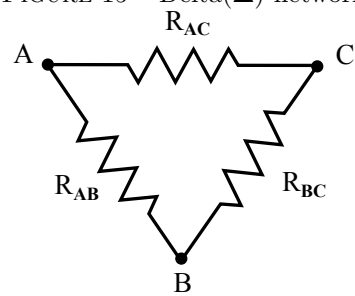

FIGURE 15 – Delta(Δ) network



To convert a Delta(Δ) to a Wye(Y)

$$R_A = \frac{R_{AB}R_{AC}}{R_{AB} + R_{AC} + R_{BC}} \quad (5.31)$$

$$R_B = \frac{R_{AB}R_{BC}}{R_{AB} + R_{AC} + R_{BC}} \quad (5.32)$$

$$R_C = \frac{R_{AC}R_{BC}}{R_{AB} + R_{AC} + R_{BC}} \quad (5.33)$$

To convert a Wye(Y) to a Delta(Δ)

$$R_{AB} = \frac{R_A R_B + R_A R_C + R_B R_C}{R_C} \quad (5.31)$$

$$R_{BC} = \frac{R_A R_B + R_A R_C + R_B R_C}{R_A} \quad (5.32)$$

$$R_{AC} = \frac{R_A R_B + R_A R_C + R_B R_C}{R_B} \quad (5.33)$$

A prime application for Δ -Y conversion is in the solution of unbalanced bridge circuits, such as the one below :

FIGURE 16 – Δ -Y conversion example

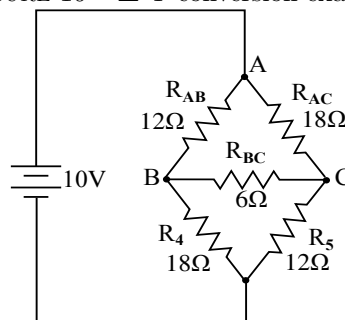

Solution of this circuit with branch current or mesh current analysis is fairly involved, however methods like those are labor-consuming. If we were to treat resistors R_{AB} , R_{AC} , R_{BC} as being connected in a Δ configuration and generate an equivalent Y network to replace them, we could turn this bridge circuit into a (simpler) series/parallel combination circuit :

FIGURE 17 – After the Δ -Y conversion

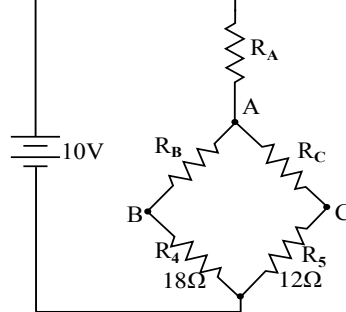

If we perform our calculation correctly, the voltages between points A , B and C will be the same in the converted circuit as in the original circuit, and we can transfer those values back to the original bridge configuration.

$$R_A = \frac{(12\Omega)(18\Omega)}{(12\Omega) + (18\Omega) + (6\Omega)} = \frac{216}{36} = 6\Omega \tag{5.34}$$

$$R_B = \frac{(12\Omega)(6\Omega)}{(12\Omega) + (18\Omega) + (6\Omega)} = \frac{72}{36} = 2\Omega \tag{5.35}$$

$$R_C = \frac{(18\Omega)(6\Omega)}{(12\Omega) + (18\Omega) + (6\Omega)} = \frac{108}{36} = 3\Omega \tag{5.36}$$

Resistors R_4 and R_5 , of course, remain the same at 18Ω and 12Ω , respectively.

5.2.3 Infinite Resistor Network

Calculate the equivalent resistance of the following circuit combined with infinite resistors.

FIGURE 18 – 1-direction infinite ladder-shape resistor combination

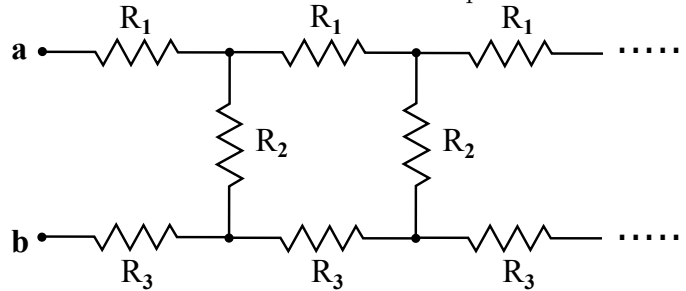

Analysis : The ladder-shape circuit above can be seen as composed with several “Part” shown in Figure 19

FIGURE 19 – Part

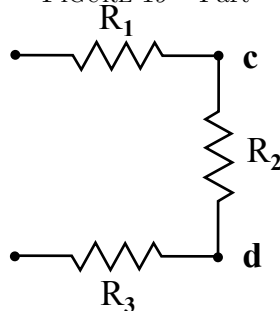

Since there are infinitely many resistors, there will still be infinitely many if we add(detach) another “Part” to the front section as shown in Figure 20, and the resistance seen looking to the right between **e** and **f** will be the same as the resistance seen between **a** and **b**. That is $R_{ef} = R_{ab}$.

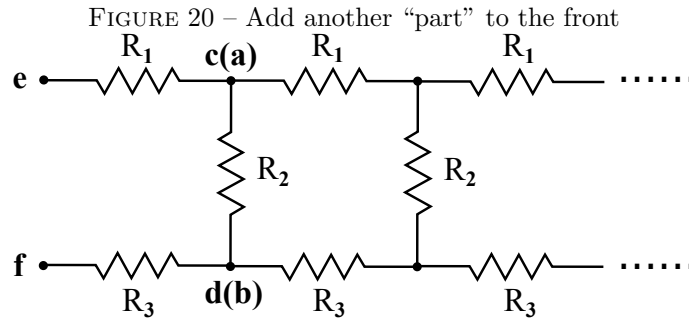

From the Figure 20, the equivalent resistance across **e** and **f** is :

$$R_{ef} = R_1 + R_3 + R_{cd}(R_{ab})$$

$$R_{ef} = R_1 + R_3 + \left(\frac{R_2 R_{ab}}{R_2 + R_{ab}}\right)$$

Recall that $R_{ef} = R_{ab}$, so R_{ab} can be expressed as :

$$R_{ab} = R_1 + R_3 + \left(\frac{R_2 R_{ab}}{R_2 + R_{ab}}\right) \tag{5.37}$$

$$R_{ab} = \frac{R_1 + R_3 + \sqrt{(R_1 + R_3)(R_1 + R_3 + 4R_2)}}{2} \tag{5.38}$$

Likewise, the following circuits have their equivalent resistances are shown as follow :

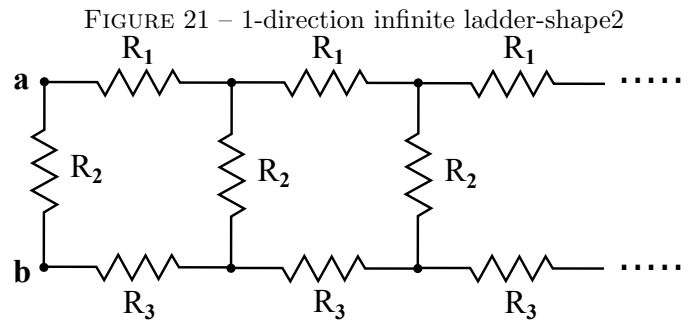

$$R_{ab} = \frac{R_1 + R_3 + \sqrt{(R_1 + R_3)(R_1 + R_3 + 4R_2)}}{2} \tag{5.39}$$

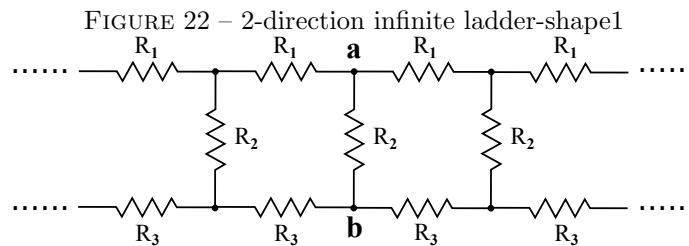

$$R_{ab} = R_2 \sqrt{\frac{(R_1 + R_3)}{(R_1 + R_3 + 4R_2)}} \tag{5.40}$$

FIGURE 23 – 2-direction infinite ladder-shape2

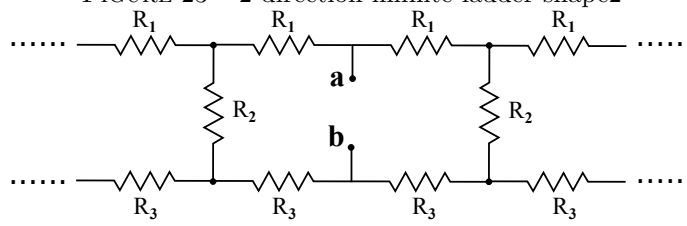

$$R_{ab} = \frac{R_1 + R_3 + \sqrt{(R_1 + R_3)(R_1 + R_3 + 4R_2)}}{4} \tag{5.41}$$

FIGURE 24 – 2-direction infinite ladder-shape3

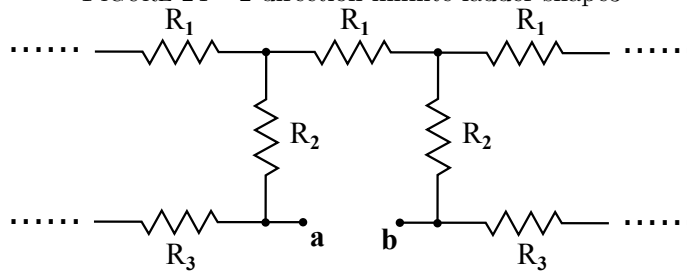

$$R_{ab} = \sqrt{(R_1 + R_3)(R_1 + R_3 + 4R_2)} - R_3 \tag{5.42}$$